

11 Displacements	(4.9 - 29.1 in ³ /rev)	
11 Schluckvolumen	81 . . . 477 cm ³ /rev	
11 Cylindrée		
11 Desplazamientos		
	Cont.	Int.
Maximum Pressure	(3000 psid)	(4000 psid)
Eingangsdruck	. . . 207 bar	. . . 276 bar
Pression entrée		
Presion Maxima		
Maximum Oil Flow	(25 gpm)	
Schluckstrom	. . . 95 lpm	
Débit d'huile		
Caudal Maximo de Aceite		
Maximum Speed	(749 rpm)	
Drehzahl	749 rpm	
Vitesse de rotation		
Velocidad Maxima		
	Cont.	Int.
Maximum Torque	(6027 lb in)	(8106 lb in)
MaxDrehmoment	681 Nm	916 Nm
Couple		
Torque Maximo		
Maximum Side Load at Key	(3597 lb)	
Seitenlast	. . . 16000 N	
Charges latérales		
Carga Maxima Lateral		

A Tough Motor for Tough Applications

Sturdy construction throughout makes Parker's TF Series motors suitable for the most severe applications. The powertrain uses patented 60:40 spline geometry for strength. All splines are constantly flushed with cool fluid for durability. Roller vanes and sealed commutation assure high volumetric efficiency, smooth low speed operation and extended life. Shaft seals can withstand full system pressure and are washed in cool fluid for long life.

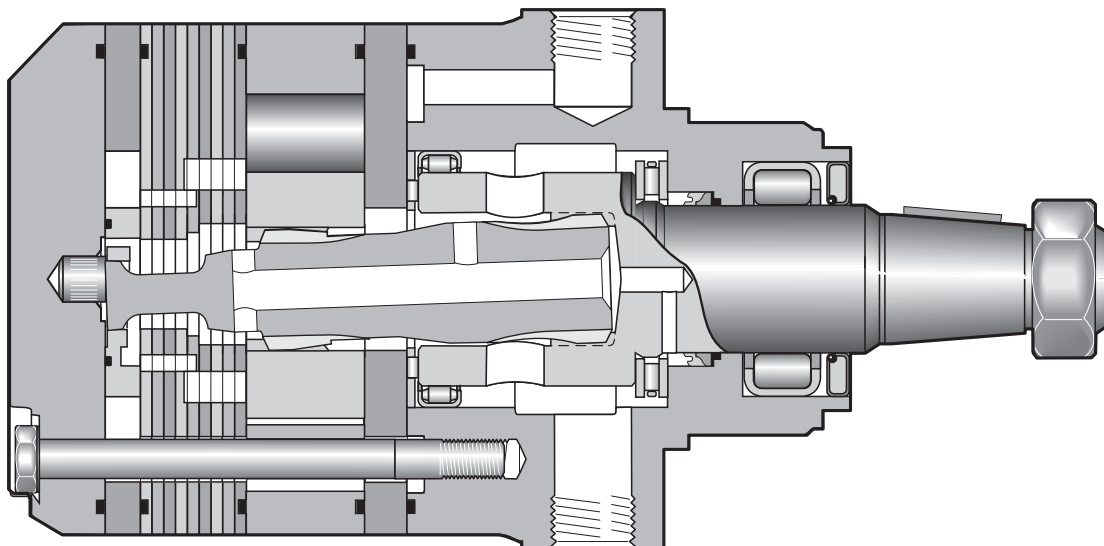
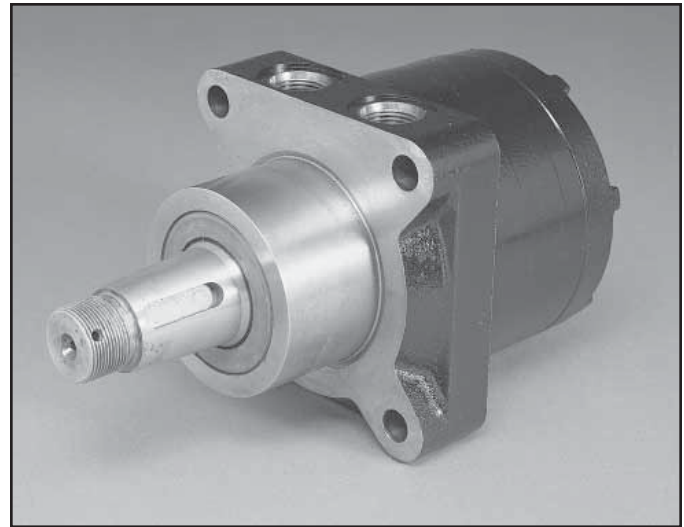

TF

Series









XXXX

Displacement
Schluckvolumen
Cylindrée
Desplazamiento

Code	cm ³ /U cm ³ /tr cm ³ /giro in ³ /rev
0080	81 / 4.9
0100	100 / 6.1
0130	128 / 7.8
0140	141 / 8.6
0170	169 / 10.3
0195	197 / 11.9
0240	238 / 14.5
0280	280 / 17.1
0360	364 / 22.2
0405	405 / 24.7
0475	477 / 29.1

X

Mounting
Gehäuse
Carter
Montaje

Code	Mounting
A	SAE "A" 2 Bolt 
B	SAE "B" 2 Bolt 
L	Wheel, Front Brake 
M	Magneto 
U	Wheel, Standard 
W*	Wheel, Optional 
D*	Large Wheel Mount 
V*	SAE "A" 4 Bolt 

*Requires rear porting

X

Ports
Anschluß
Plan de raccordement
Lumbreras

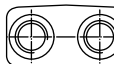
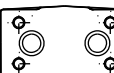
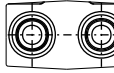
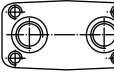
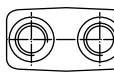









Code	Ports
A	7/8-14 SAE O-Ring; Rear Axial 
B	7/8-14 SAE O-Ring; Rear Radial 
E	Manifold; Rear Radial 
H	ISO 6149 M22 x 1.5 
M*	5/16-18 UNC Manifold 
S	7/8-14 SAE 

*Not available on L, U or W mounting.

For other available options, see pages 261–262.



XX

Shaft
Welle
Arbre
Eje

Code	Shaft
01*	1" 6B Spline 
02*	1" Keyed 
03	1 1/4" Keyed 
04	10B Spline 
05	1 1/4" 14 Tooth Spline 
06	19 Tooth Spline 
07	15 Tooth Spline 
08	1 1/4" Tapered 
22	25mm Keyed 
28	13 Tooth Spline 
46	32mm Keyed 

0

Rotation
Drehrichtung
Direction de rotation
Rotacion

Code	Rotation
0	Standard B ↑ ↓ A 
1	Reverse Timed Manifold B ↑ ↓ A 

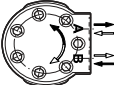
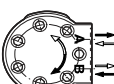
Code	Rear Rotation
0	Standard 
1	Reverse Timed Manifold 

Rotation viewed from shaft end.

XXXX

Options
Opciones

Code	Options
AAAA	Black Paint
AAAB	No Paint
AAAC	Double Paint
AAAF***	Castle Nut, Black Paint
AABP***	Castle Nut, No Paint
AAAG	Viton Seals, Black Paint
AAAH	Viton Seals, No Paint
AAAJ	High Temperature Commutator Seal, Black Paint
AAFG	High Temperature Commutator Seal, No Paint
AAAT*	Bidirectional Shuttle (11:00**), Black Paint
AAFX*	Bidirectional Shuttle (11:00**), No Paint
AAAU*	Bidirectional Shuttle (11:00**), Castle Nut, Black Paint
AAGF*	Bidirectional Shuttle (11:00**), Castle Nut, No Paint
AABJ	Free Running Rotorset, Black Paint
AABK	Free Running Rotorset, No Paint
AABL	Free Running Rotorset, No Commutator Seal, Black Paint
AABM	Free Running Rotorset, No Commutator Seal, No Paint

- * Not available with A, B or E porting
- ** Shuttle port position as viewed from shaft end of motor
- *** Available only with shaft code 08

* Abtriebswelle Ø 25mm Max. Moment cont./int. }
Coupling shaft Ø 1 inch Max. torque cont./int. } 450/550 Nm
Arbre 6B SAE Couple maxi cont./int. }
Eje de acoplamiento Coppia max cont./int. }

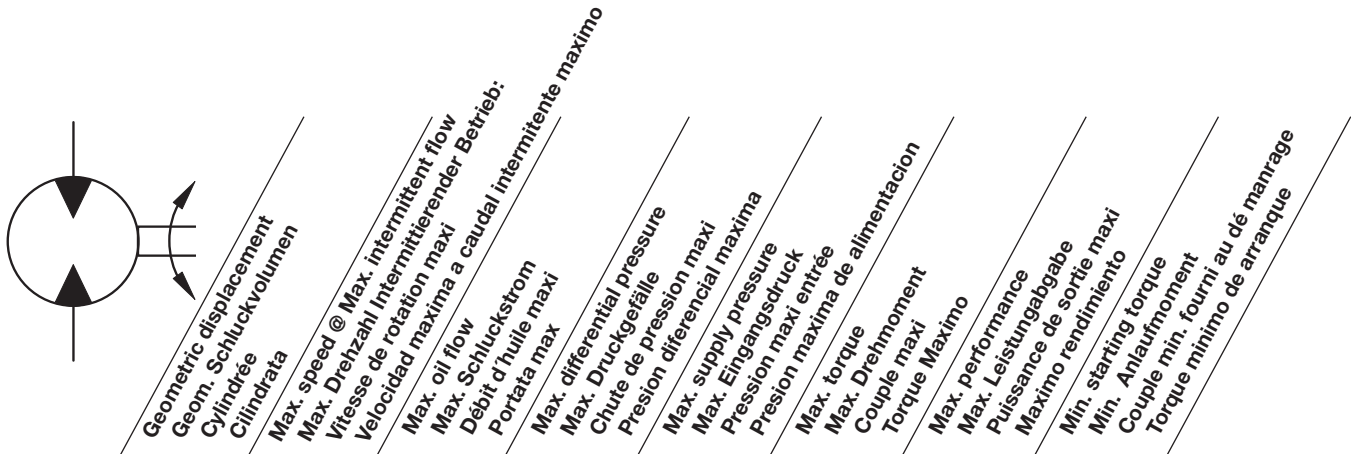

Motor Series TF	cm³/rev in³/rev	rev/min	cont / int* l/min g/min		cont / int* bar psid		max bar psig	cont / int* Nm lb-in		max KW HP	cont / int* Nm lb-in	
TF 0080	81 4.9	693	46 12	57 15	207 3000	276 4000	300 4350	220 1948	296 2621	21.5 28.8	158 1401	205 1811
TF 0100	100 6.1	749	57 15	76 20	155 2250	241 3500	300 4350	197 1746	318 2813	24.9 33.4	148 1309	243 2155
TF 0130	128 7.8	583	57 15	76 20	138 2000	207 3000	300 4350	229 2031	356 3148	21.7 29.1	180 1596	278 2460
TF 0140	141 8.6	530	57 15	76 20	138 2000	207 3000	300 4350	254 2248	393 3477	21.8 29.2	196 1739	308 2728
TF 0170	169 10.3	444	57 15	76 20	138 2000	207 3000	300 4350	317 2808	489 4324	22.7 30.5	243 2152	385 3404
TF 0195	197 12.0	381	57 15	76 20	138 2000	207 3000	300 4350	364 3222	562 4971	22.4 30.1	302 2671	468 4142
TF 0240	238 14.5	394	76 20	95 25	138 2000	207 3000	300 4350	427 3782	670 5928	27.7 37.1	366 3242	572 5058
TF 0280	280 17.1	334	76 20	95 25	138 2000	207 3000	300 4350	509 4502	794 7029	27.8 37.3	438 3876	672 5946
TF 0360	364 22.2	258	76 20	95 25	130 1880	190 2750	300 4350	594 5257	880 7788	20.0 26.8	517 4575	779 6898
TF 0365 Clutch	364 22.2	258	76 20	95 25	97 1400	152 2200	300 4350	437 3871	740 6456	20.0 26.8	398 3521	650 5749
TF 0405	405 24.7	231	76 20	95 25	128 1850	172 2750	300 4350	655 5800	916 8106	22.1 29.7	575 5091	789 6978
TF 0475	477 29.1	195	76 20	95 25	113 1645	138 2000	300 4350	681 6027	851 7528	17.4 23.3	603 5334	740 6548

Performance data based on testing using 10W40 oil with a viscosity of 43.1 cSt (200 SUS) at 54° C (130° F). Performance data is typical. Actual data may vary slightly from one production motor to another.

Les données sur les performances sont basées sur des tests utilisant de l'huile 10W40 d'une viscosité de 200 SUS à 54°C (130°F). Ces données correspondent à des situations typiques. Les données réelles peuvent varier légèrement d'un moteur de production à l'autre.

Leistungsdaten sind gemessen mit SAE 10W40 bei einer Viskosität von 43,1 Cst bei 54°C. Geringfügige Abweichungen von den Katalogdaten sind möglich.

Datos técnicos obtenidos con aceite 10W40 de 200 SUS de viscosidad a 54°C (130°F). Los datos proporcionados son valores típicos. Los valores exactos reales podrían tener una pequeña variación entre distintos motores.

* Intermittent operation rating applies to 10% of every minute.
Intermittierende Werte maximal 10% von jeder Betriebsminute.
Fonctionnement interm. 10% max. de chaque minute d'utilisation.
Capacidad de funcionamiento intermitente válida para 10% por cada minuto.

TF 0080

4.9 cu in / rev

PRESSURE (PSID)

	500	1000	1500	2000	2500	3000	3500	4000
.5	256 19	546 14	835 8	1118 1				
1	270 42	575 37	867 31	1151 24	1434 17	1713 13	2002 12	2289 13
2	281 89	598 83	917 76	1233 68	1537 60	1821 53	2090 46	2352 40
3	282 135	601 128	922 121	1238 113	1547 104	1845 96	2138 86	2428 78
4	284 182	610 174	938 166	1264 158	1586 149	1899 139	2202 129	2491 120
5	282 228	612 219	944 211	1278 202	1607 193	1932 183	2250 172	2560 163
7	274 321	607 311	945 301	1285 291	1622 281	1957 270	2288 258	2612 247
9	262 414	597 402	937 391	1279 380	1622 369	1960 357	2295 344	2628 331
12	239 553	574 540	916 526	1260 514	1605 501	1948 488	2287 472	2621 456
15	215 693	546 677	886 661	1231 646	1579 633	1927 619	2269 601	2605 582

Flow (GPM)

TORQUE (LB IN) 2605
SPEED (RPM) 582

81 cc / rev

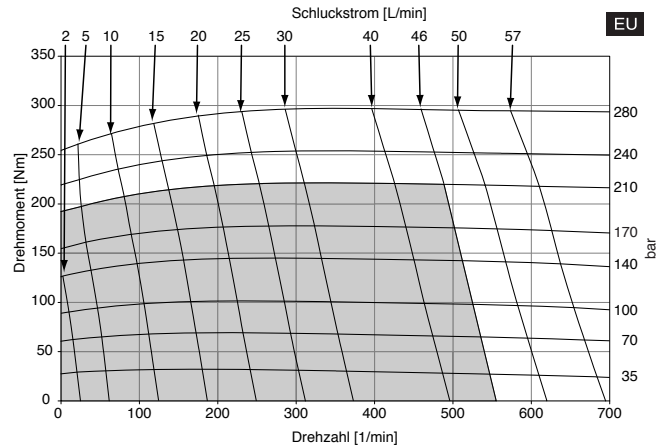

Cont.

Int.

Intermittent operation rating applies to 10% of every minute.

Fonctionnement interm. 10% max. de chaque minute d'utilisation.

Performance data based on testing using 10W40 oil with a viscosity of 200 SUS at 54° C (130° F). Performance data is typical. Actual data may vary slightly from one production motor to another.

Les données sur les performances sont basées sur des tests utilisant de l'huile 10W40 d'une viscosité de 200 SUS à 54°C (130°F). Ces données correspondent à des situations typiques. Les données réelles peuvent varier légèrement d'un moteur de production à l'autre.

Intermittierende Werte maximal 10% von jeder Betriebsminute.

Capacidad de funcionamiento intermitente valida para 10% por cada minuto. Leistungsdaten sind gemessen mit SAE 10W40 bei einer Viskosität von 43,1 Cst bei 54°C. Geringfügige Abweichungen von den Katalogerten sind möglich.

Datos tecnicos obtenidos con aceite 10W40 de 200 SUS de viscosidad a 54°C (130°F). Los datos proporcionados son valores típicos. Los valores exactos reales podrían tener una pequeña variación entre distintos motores.

TF 0100

6.1 cu in / rev

PRESSURE (PSID)

	500	1000	1500	2000	2250	2500	3000	3500
.5	318 14	679 9	1041 4					
1	335 33	703 28	1066 22	1430 17	1611 14	1791 12	2162 9	2543 6
2	351 71	743 65	1132 58	1514 52	1700 48	1882 45	2241 39	2602 34
3	350 109	746 102	1138 95	1525 88	1717 84	1907 80	2288 72	2671 64
4	353 147	754 139	1156 132	1554 124	1752 120	1948 116	2334 107	2716 98
5	352 184	759 177	1167 169	1572 161	1774 156	1974 152	2370 143	2762 133
7	343 260	753 252	1166 243	1581 233	1788 229	1994 224	2401 213	2810 202
9	329 336	741 327	1159 316	1579 306	1788 301	1997 296	2411 284	2824 272
12	299 449	715 438	1137 426	1561 415	1773 409	1985 403	2406 391	2825 377
15	259 562	679 549	1106 536	1532 523	1746 517	1959 510	2387 496	2813 480
20	186 749	607 734	1034 718	1463 703	1679 696	1896 689	2331 671	2763 653

Flow (GPM)

TORQUE (LB IN) 2763
SPEED (RPM) 653

100 cc / rev

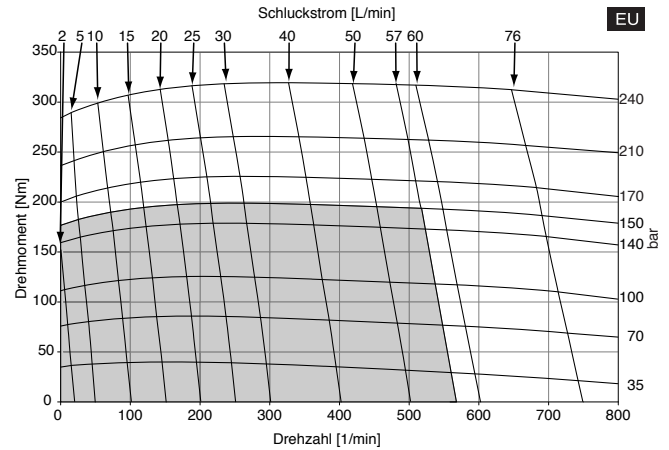

Cont.

Int.

Intermittent operation rating applies to 10% of every minute.

Fonctionnement interm. 10% max. de chaque minute d'utilisation.

Performance data based on testing using 10W40 oil with a viscosity of 200 SUS at 54° C (130° F). Performance data is typical. Actual data may vary slightly from one production motor to another.

Les donnees sur les performances sont basees sur des tests utilisant de l'huile 10W40 d'une viscosite de 200 SUS a 54°C (130°F). Ces donnees correspondent a des situations typiques. Les donnees reelles peuvent varier legerement d'un moteur de production a l'autre.

008 TF.indd, js

Intermittierende Werte maximal 10% von jeder Betriebsminute.

Capacidad de funcionamiento intermitente valida para 10% por cada minuto. Leistungsdaten sind gemessen mit SAE 10W40 bei einer Viskositat von 43,1 Cst bei 54°C. Geringfügige Abweichungen von den Katalogerten sind möglich.

Datos tecnicos obtenidos con aceite 10W40 de 200 SUS de viscosidad a 54°C (130°F). Los datos proporcionados son valores tipicos. Los valores exactos reales podrian tener una pequena variacion entre distintos motores.

TF 0130

7.8 cu in / rev

PRESSURE (PSID)

	500	1000	1500	2000	2500	3000
.5	441 10	927 7	1413 3			
1	456 24	948 21	1440 17	1935 13	2422 9	2909 5
2	478 52	991 47	1495 42	2004 36	2508 32	3009 29
3	475 82	993 76	1510 70	2023 63	2533 57	3042 52
4	479 112	1006 105	1529 98	2048 91	2568 85	3084 79
5	478 141	1014 134	1548 127	2076 119	2600 113	3115 106
7	467 200	1010 192	1553 184	2094 176	2632 169	3166 161
9	447 259	996 251	1546 242	2094 233	2640 225	3184 216
12	410 348	961 338	1518 328	2073 318	2626 309	3177 299
15	365 436	914 426	1474 415	2031 404	2589 394	3148 382
20	263 583	812 572	1371 559	1933 547	2498 535	3059 522

Flow (GPM)

TORQUE (LB IN) 3059
SPEED (RPM) 522

128 cc / rev

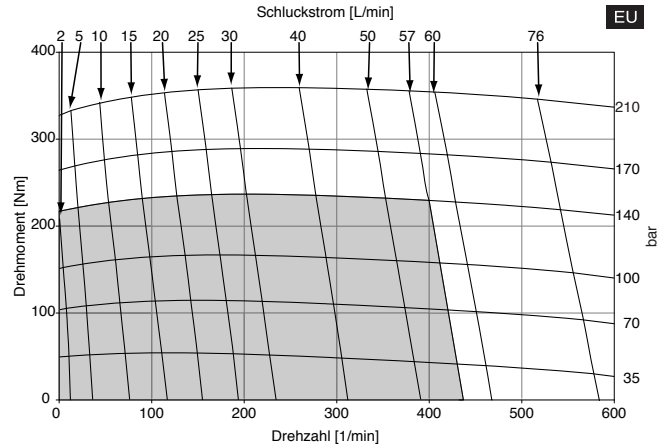

Cont.

Int.

Intermittent operation rating applies to 10% of every minute.

Fonctionnement interm. 10% max. de chaque minute d'utilisation.

Performance data based on testing using 10W40 oil with a viscosity of 200 SUS at 54° C (130° F). Performance data is typical. Actual data may vary slightly from one production motor to another.

Les données sur les performances sont basées sur des tests utilisant de l'huile 10W40 d'une viscosité de 200 SUS à 54°C (130°F). Ces données correspondent à des situations typiques. Les données réelles peuvent varier légèrement d'un moteur de production à l'autre.

Intermittierende Werte maximal 10% von jeder Betriebsminute.

Capacidad de funcionamiento intermitente valida para 10% por cada minuto. Leistungsdaten sind gemessen mit SAE 10W40 bei einer Viskosität von 43,1 Cst bei 54°C. Geringfügige Abweichungen von den Katalogerten sind möglich.

Datos tecnicos obtenidos con aceite 10W40 de 200 SUS de viscosidad a 54°C (130°F). Los datos proporcionados son valores tipicos. Los valores exactos reales podrian tener una pequena variacion entre distintos motores.

TF 0140

8.6 cu in / rev

PRESSURE (PSID)

	500	1000	1500	2000	2500	3000
.5	485 11	1025 8	1560 4			
1	507 24	1056 20	1594 16	2137 12	2682 8	3224 5
2	526 50	1101 46	1670 42	2237 37	2796 33	3336 28
3	525 77	1103 72	1676 68	2246 63	2814 57	3370 52
4	528 103	1114 98	1696 93	2277 88	2857 82	3423 77
5	528 130	1120 125	1712 119	2301 113	2885 107	3456 101
7	516 184	1115 177	1716 170	2314 164	2908 158	3497 151
9	496 237	1100 230	1707 222	2311 215	2912 208	3510 200
12	454 317	1063 309	1677 300	2290 292	2901 284	3506 275
15	403 397	1011 388	1629 378	2248 368	2866 359	3477 349
20	298 530	908 520	1525 508	2149 497	2775 485	3401 473

Flow (GPM)

TORQUE (LB IN) 3401
SPEED (RPM) 473

141 cc / rev

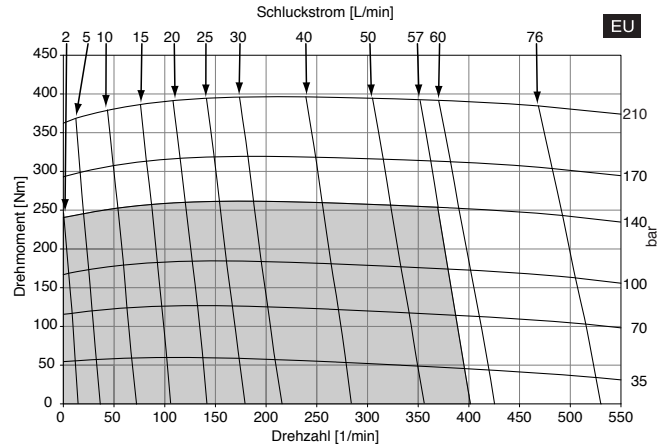

Cont.

Int.

Intermittent operation rating applies to 10% of every minute.

Fonctionnement interm. 10% max. de chaque minute d'utilisation.

Performance data based on testing using 10W40 oil with a viscosity of 200 SUS at 54° C (130° F). Performance data is typical. Actual data may vary slightly from one production motor to another.

Les donnees sur les performances sont basees sur des tests utilisant de l'huile 10W40 d'une viscosite de 200 SUS a 54°C (130°F). Ces donnees correspondent a des situations typiques. Les donnees reelles peuvent varier legerement d'un moteur de production a l'autre.

Intermittierende Werte maximal 10% von jeder Betriebsminute.

Capacidad de funcionamiento intermitente valida para 10% por cada minuto. Leistungsdaten sind gemessen mit SAE 10W40 bei einer Viskositat von 43,1 Cst bei 54°C. Geringfügige Abweichungen von den Katalogerten sind möglich.

Datos tecnicos obtenidos con aceite 10W40 de 200 SUS de viscosidad a 54°C (130°F). Los datos proporcionados son valores tipicos. Los valores exactos reales podrian tener una pequena variacion entre distintos motores.

TF 0170

10.3 cu in / rev

PRESSURE (PSID)

	500	1000	1500	2000	2500	3000
.5	627 8	1304 6	1980 2			
1	657 19	1341 16	2021 12	2714 9	3404 4	4101 1
2	687 42	1409 38	2123 34	2829 29	3520 25	4197 21
3	681 64	1407 60	2127 56	2841 51	3552 45	4263 40
4	681 86	1419 82	2153 77	2879 72	3604 67	4321 61
5	675 109	1423 104	2165 99	2897 94	3628 88	4355 82
7	654 153	1406 148	2161 143	2911 137	3652 130	4385 123
9	624 198	1380 193	2143 186	2900 180	3645 173	4384 165
12	572 265	1331 259	2101 252	2863 244	3618 236	4364 228
15	514 332	1267 325	2040 317	2808 309	3570 300	4324 291
20	387 444	1138 436	1903 427	2667 417	3435 407	4201 396

Flow (GPM)

TORQUE (LB IN) 4201
SPEED (RPM) 396

169 cc / rev

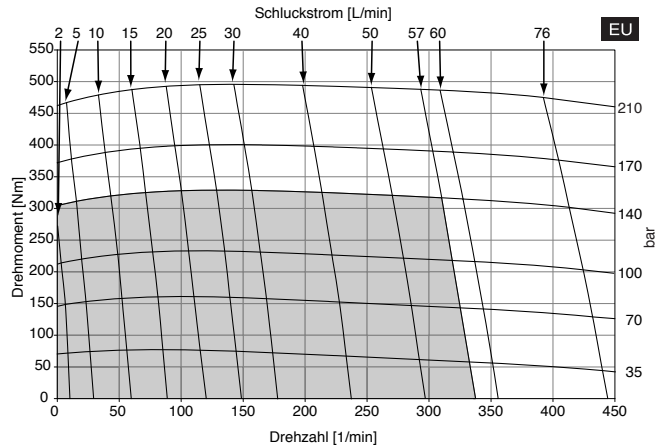

Cont.

Int.

Intermittent operation rating applies to 10% of every minute.

Fonctionnement interm. 10% max. de chaque minute d'utilisation.

Performance data based on testing using 10W40 oil with a viscosity of 200 SUS at 54° C (130° F). Performance data is typical. Actual data may vary slightly from one production motor to another.

Les donnees sur les performances sont basees sur des tests utilisant de l'huile 10W40 d'une viscosite de 200 SUS a 54°C (130°F). Ces donnees correspondent a des situations typiques. Les donnees reelles peuvent varier legerement d'un moteur de production a l'autre.

Intermittierende Werte maximal 10% von jeder Betriebsminute.

Capacidad de funcionamiento intermitente valida para 10% por cada minuto. Leistungsdaten sind gemessen mit SAE 10W40 bei einer Viskositat von 43,1 Cst beo 54°C. Geringfügige Abweichungen von den Katalogerten sond möglich.

Datos tecnicos obtenidos con aceite 10W40 de 200 SUS de viscosidad a 54°C (130°F). Los datos proporcionados son valores tipcos. Los valores exactos reales podrian tener una pequena variacion entre distintos motores.

TF 0195

12.0 cu in / rev

PRESSURE (PSID)

	500	1000	1500	2000	2500	3000
.5	710 8	1494 7	2286 5	3085 3		
1	737 18	1537 16	2334 14	3133 12	3946 9	4767 7
2	757 37	1587 35	2417 32	3242 29	4067 26	4887 23
3	758 56	1591 53	2424 51	3254 47	4086 44	4914 40
4	759 75	1604 72	2450 69	3292 66	4131 62	4965 58
5	755 94	1610 91	2469 88	3321 84	4163 80	5000 75
7	737 132	1599 129	2467 125	3329 120	4185 116	5034 110
9	709 170	1577 166	2451 162	3319 157	4181 152	5034 146
12	652 228	1523 223	2405 218	3283 212	4154 206	5018 199
15	586 285	1451 280	2338 273	3222 267	4100 260	4971 252
20	445 381	1303 375	2174 367	3056 359	3939 350	4822 341

Flow (GPM)

TORQUE (LB IN) 4822
SPEED (RPM) 341

197 cc / rev

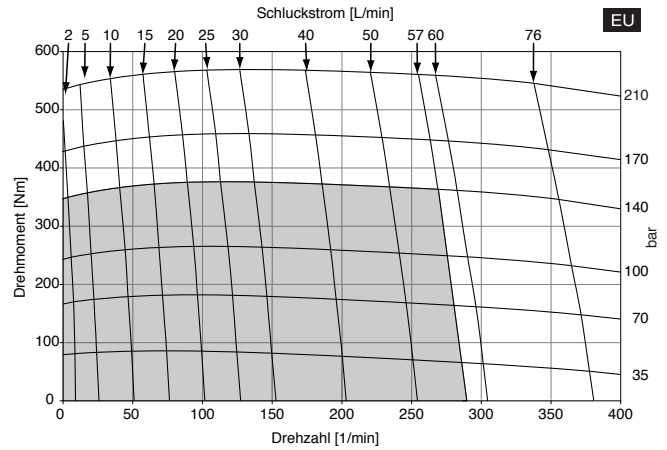

Cont.

Int.

Intermittent operation rating applies to 10% of every minute.

Fonctionnement interm. 10% max. de chaque minute d'utilisation.

Performance data based on testing using 10W40 oil with a viscosity of 200 SUS at 54° C (130° F). Performance data is typical. Actual data may vary slightly from one production motor to another.

Les donnees sur les performances sont basees sur des tests utilisant de l'huile 10W40 d'une viscosite de 200 SUS a 54°C (130°F). Ces donnees correspondent a des situations typiques. Les donnees reelles peuvent varier legerement d'un moteur de production a l'autre.

008 TF.indd, js

Intermittierende Werte maximal 10% von jeder Betriebsminute.

Capacidad de funcionamiento intermitente valida para 10% por cada minuto.

Leistungsdaten sind gemessen mit SAE 10W40 bei einer Viskositat von 43,1 Cst bei 54°C. Geringfügige Abweichungen von den Katalogerten sind möglich.

Datos tecnicos obtenidos con aceite 10W40 de 200 SUS de viscosidad a 54°C (130°F). Los datos proporcionados son valores tipicos. Los valores exactos reales podrian tener una pequena variacion entre distintos motores.

TF 0240

14.5 cu in / rev

PRESSURE (PSID)

	500	1000	1500	2000	2500	3000
.5	856 7	1796 5	2758 3	3739 1		
1	883 15	1838 13	2801 11	3780 8	4756 5	5741 3
2	920 30	1912 28	2910 26	3895 23	4880 20	5864 17
3	919 46	1920 44	2927 41	3931 38	4924 35	5919 31
4	924 62	1941 60	2958 57	3967 54	4978 50	5985 45
5	919 78	1948 75	2975 72	3998 69	5017 64	6025 60
7	904 109	1947 106	2995 103	4036 99	5066 94	6090 89
9	868 141	1922 137	2982 134	4033 130	5072 124	6101 119
12	815 188	1866 184	2930 180	3998 175	5053 169	6090 162
15	726 235	1791 231	2865 227	3934 221	5002 214	6054 206
20	539 315	1616 310	2699 304	3782 297	4863 289	5928 280
25	335 394	1404 389	2464 382	3542 374	4634 365	5718 354

Flow (GPM)

TORQUE (LB IN) 5718
SPEED (RPM) 354

238 cc / rev

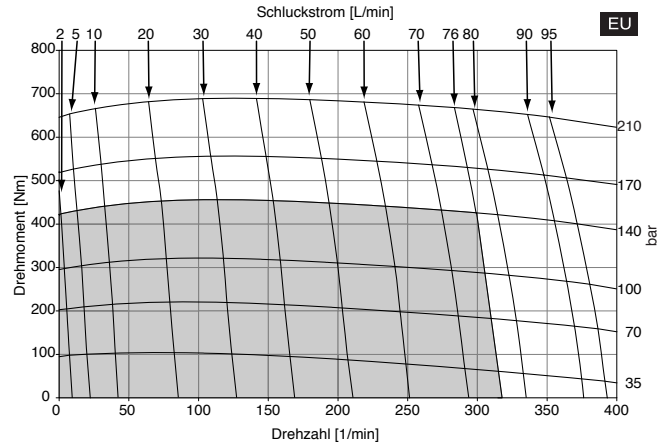

Cont.

Int.

Intermittent operation rating applies to 10% of every minute.

Fonctionnement interm. 10% max. de chaque minute d'utilisation.

Performance data based on testing using 10W40 oil with a viscosity of 200 SUS at 54° C (130° F). Performance data is typical. Actual data may vary slightly from one production motor to another.

Les données sur les performances sont basées sur des tests utilisant de l'huile 10W40 d'une viscosité de 200 SUS à 54°C (130°F). Ces données correspondent à des situations typiques. Les données réelles peuvent varier légèrement d'un moteur de production à l'autre.

Intermittierende Werte maximal 10% von jeder Betriebsminute.

Capacidad de funcionamiento intermitente valida para 10% por cada minuto. Leistungsdaten sind gemessen mit SAE 10W40 bei einer Viskosität von 43,1 Cst bei 54°C. Geringfügige Abweichungen von den Katalogerten sind möglich.

Datos tecnicos obtenidos con aceite 10W40 de 200 SUS de viscosidad a 54°C (130°F). Los datos proporcionados son valores tipicos. Los valores exactos reales podrian tener una pequena variacion entre distintos motores.

TF 0280

17.1 cu in / rev

	PRESSURE (PSID)					
	500	1000	1500	2000	2500	3000
.5	1048 6	2180 5	3333 4	4508 3	5704	
1	1080 13	2237 12	3399 11	4577 9	5762 7	6925 5
2	1120 26	2316 25	3516 23	4726 22	5915 19	7092 17
3	1117 39	2320 38	3528 36	4742 34	5949 32	7134 29
4	1120 53	2337 51	3559 49	4778 47	5988 44	7187 41
5	1109 66	2342 64	3575 62	4802 60	6020 56	7218 53
7	1086 93	2331 91	3582 88	4827 85	6058 81	7266 77
9	1040 120	2299 117	3562 114	4811 111	6048 106	7264 102
12	978 160	2226 157	3494 154	4758 149	6001 144	7217 138
15	888 200	2146 197	3419 193	4688 188	5945 182	7176 175
20	678 267	1945 263	3223 258	4502 252	5777 245	7029 236
25	442 334	1686 330	2938 324	4206 316	5487 308	6754 297

Flow (GPM)

TORQUE (LB IN) 6754
SPEED (RPM) 297

280 cc / rev

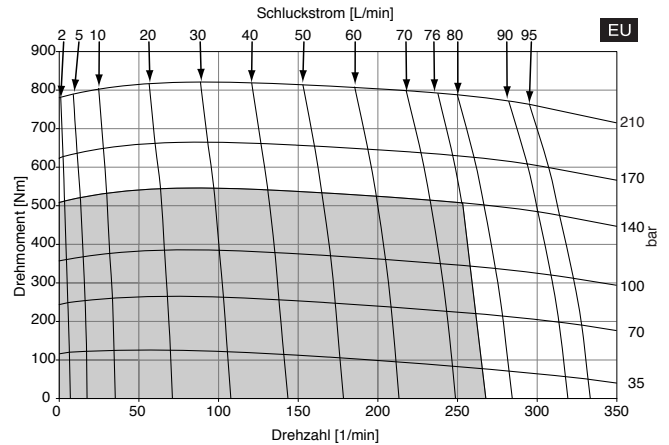

Cont.

Int.

Intermittent operation rating applies to 10% of every minute.

Fonctionnement interm. 10% max. de chaque minute d'utilisation.

Performance data based on testing using 10W40 oil with a viscosity of 200 SUS at 54° C (130° F). Performance data is typical. Actual data may vary slightly from one production motor to another.

Les données sur les performances sont basées sur des tests utilisant de l'huile 10W40 d'une viscosité de 200 SUS à 54°C (130°F). Ces données correspondent à des situations typiques. Les données réelles peuvent varier légèrement d'un moteur de production à l'autre.

Intermittierende Werte maximal 10% von jeder Betriebsminute.

Capacidad de funcionamiento intermitente valida para 10% por cada minuto. Leistungsdaten sind gemessen mit SAE 10W40 bei einer Viskosität von 43,1 Cst bei 54°C. Geringfügige Abweichungen von den Katalogerten sind möglich.

Datos tecnicos obtenidos con aceite 10W40 de 200 SUS de viscosidad a 54°C (130°F). Los datos proporcionados son valores tipicos. Los valores exactos reales podrian tener una pequena variacion entre distintos motores.

TF 0360

22.2 cu in / rev

	PRESSURE (PSID)							
	500	1000	1500	1850	2000	2500	2750	
.5	1436 5	2955 4	4497 4	5582 4	6047 3	7608 3	8393 3	
1	1492 10	3042 9	4591 9	5672 8	6136 8	7673 8	8445 7	
2	1532 20	3114 19	4691 19	5784 18	6249 18	7799 17	8575 16	
3	1527 30	3114 29	4699 29	5796 28	6263 27	7814 26	8590 25	
4	1526 40	3125 40	4718 38	5821 37	6290 37	7847 35	8624 34	
5	1504 51	3114 50	4719 48	5831 47	6304 46	7866 44	8641 43	
7	1469 71	3090 70	4697 68	5809 66	6282 66	7850 63	8630 61	
9	1392 92	3017 90	4640 88	5766 86	6243 85	7817 81	8595 79	
12	1279 122	2902 120	4526 117	5653 115	6133 113	7712 109	8493 106	
15	1106 153	2739 151	4385 147	5518 144	5999 142	7578 139	8355 134	
20	840 204	2465 202	4115 197	5256 193	5735 191	7329 184	8121 180	
25	516 255	2138 253	3756 248	4876 243	5356 240	6976 232	7785 226	

Flow (GPM)

TORQUE (LB IN) 7785
SPEED (RPM) 226

364 cc / rev

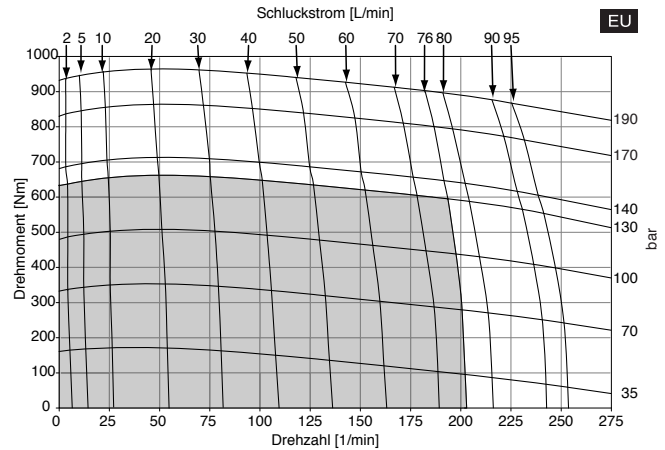

Cont.

Int.

Intermittent operation rating applies to 10% of every minute.

Fonctionnement interm. 10% max. de chaque minute d'utilisation.

Performance data based on testing using 10W40 oil with a viscosity of 200 SUS at 54° C (130° F). Performance data is typical. Actual data may vary slightly from one production motor to another.

Les données sur les performances sont basées sur des tests utilisant de l'huile 10W40 d'une viscosité de 200 SUS à 54°C (130°F). Ces données correspondent à des situations typiques. Les données réelles peuvent varier légèrement d'un moteur de production à l'autre.

Intermittierende Werte maximal 10% von jeder Betriebsminute.

Capacidad de funcionamiento intermitente valida para 10% por cada minuto. Leistungsdaten sind gemessen mit SAE 10W40 bei einer Viskosität von 43,1 Cst bei 54°C. Geringfügige Abweichungen von den Katalogerten sind möglich.

Datos tecnicos obtenidos con aceite 10W40 de 200 SUS de viscosidad a 54°C (130°F). Los datos proporcionados son valores tipicos. Los valores exactos reales podrian tener una pequena variacion entre distintos motores.

TF 0405

24.7 cu in / rev

	PRESSURE (PSID)					
	500	1000	1500	1850	2000	2500
.5	1567 4	3212 4	4883 3	6075 2	6587 2	8325 2
1	1623 9	3298 8	4972 7	6151 6	6660 6	8371 5
2	1662 18	3377 17	5103 16	6306 14	6815 14	8507 12
3	1665 27	3392 26	5118 24	6325 23	6839 22	8554 20
4	1667 37	3414 35	5155 33	6367 32	6880 31	8591 28
5	1652 46	3417 44	5171 42	6393 40	6909 39	8625 36
7	1623 64	3399 62	5163 60	6392 58	6912 56	8638 53
9	1549 83	3337 81	5125 78	6361 75	6883 73	8605 69
12	1432 111	3216 108	5006 104	6252 101	6779 99	8523 94
15	1259 138	3059 136	4866 131	6113 128	6644 126	8394 120
20	936 185	2735 182	4542 177	5800 172	6335 170	8106 162
25	657 231	2435 229	4187 222	5418 217	5945 214	7709 205

Flow (GPM)

TORQUE (LB IN) 7709
SPEED (RPM) 205

405 cc / rev

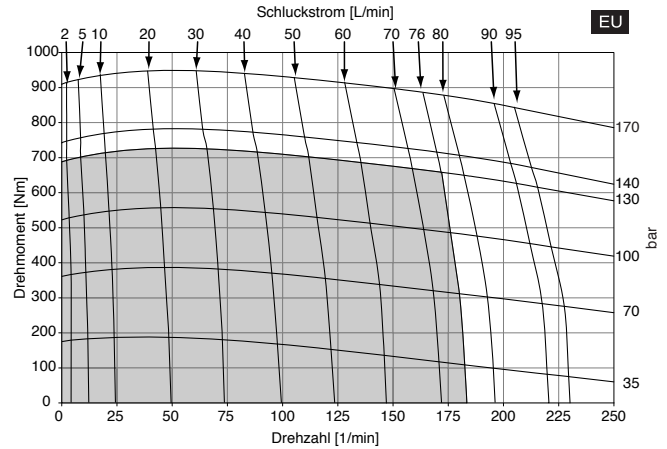

Cont.

Int.

Intermittent operation rating applies to 10% of every minute.

Fonctionnement interm. 10% max. de chaque minute d'utilisation.

Performance data based on testing using 10W40 oil with a viscosity of 200 SUS at 54° C (130° F). Performance data is typical. Actual data may vary slightly from one production motor to another.

Les données sur les performances sont basées sur des tests utilisant de l'huile 10W40 d'une viscosité de 200 SUS à 54°C (130°F). Ces données correspondent à des situations typiques. Les données réelles peuvent varier légèrement d'un moteur de production à l'autre.

Intermittierende Werte maximal 10% von jeder Betriebsminute.

Capacidad de funcionamiento intermitente valida para 10% por cada minuto. Leistungsdaten sind gemessen mit SAE 10W40 bei einer Viskosität von 43,1 Cst bei 54°C. Geringfügige Abweichungen von den Katalogerten sind möglich.

Datos tecnicos obtenidos con aceite 10W40 de 200 SUS de viscosidad a 54°C (130°F). Los datos proporcionados son valores tipicos. Los valores exactos reales podrian tener una pequena variacion entre distintos motores.

TF 0475

29.1 cu in / rev

	PRESSURE (PSID)					
	500	1000	1500	1645	1850	2000
.5	1870 4	3857 3	5875 3	6460 3	7292 2	7902 2
1	1941 8	3967 7	5992 7	6582 6	7410 6	8016 6
2	2003 15	4071 15	6124 14	6717 14	7554 13	8166 13
3	1994 23	4072 23	6145 22	6738 21	7578 20	8192 20
4	1993 31	4091 30	6177 29	6776 28	7620 27	8235 27
5	1964 39	4081 38	6186 37	6790 36	7639 35	8258 34
7	1918 55	4048 54	6159 52	6765 51	7620 50	8242 48
9	1829 70	3965 59	6098 67	6709 66	7565 64	8189 63
12	1694 94	3822 92	5954 89	6575 89	7440 87	8063 85
15	1462 117	3617 116	5766 112	6385 111	7254 109	7875 107
20	1070 156	3231 154	5394 151	6027 149	6900 147	7530 145
25	711 195	2820 194	4927 190	5531 188	6391 185	7028 183

Flow (GPM)

TORQUE (LB IN) 7028
SPEED (RPM) 183

477 cc / rev

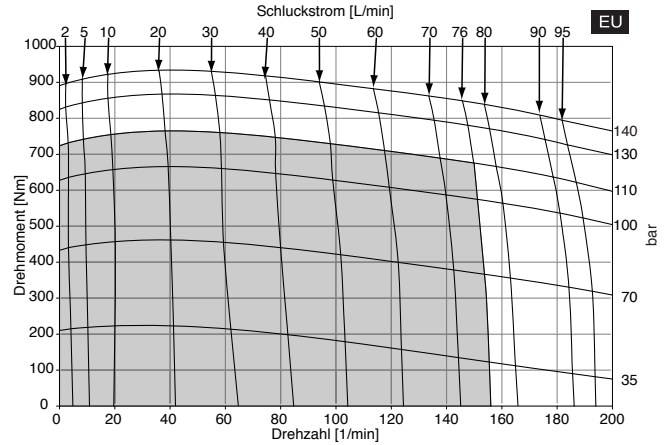

Cont.

Int.

Intermittent operation rating applies to 10% of every minute.

Fonctionnement interm. 10% max. de chaque minute d'utilisation.

Performance data based on testing using 10W40 oil with a viscosity of 200 SUS at 54° C (130° F). Performance data is typical. Actual data may vary slightly from one production motor to another.

Les donnees sur les performances sont basees sur des tests utilisant de l'huile 10W40 d'une viscosite de 200 SUS a 54°C (130°F). Ces donnees correspondent a des situations typiques. Les donnees reelles peuvent varier legerement d'un moteur de production a l'autre.

Intermittierende Werte maximal 10% von jeder Betriebsminute.

Capacidad de funcionamiento intermitente valida para 10% por cada minuto. Leistungsdaten sind gemessen mit SAE 10W40 bei einer Viskositat von 43,1 Cst beo 54°C. Geringfügige Abweichungen von den Katalogerten sond möglich.

Datos tecnicos obtenidos con aceite 10W40 de 200 SUS de viscosidad a 54°C (130°F). Los datos proporcionados son valores tipcos. Los valores exactos reales podrian tener una pequena variacion entre distintos motores.

TF 0365 Clutch Motor

22.2 cu in / rev

364 cc / rev

	PRESSURE (PSID)					
	500	1000	1400	1500	2000	2200
.5	1392 5	2902 4	4131 3	4441 3	6013 2	6653 2
1	1439 10	2972 9	4208 8	4518 8	6090 7	6725 7
2	1478 20	3061 19	4332 18	4651 18	6248 17	6884 16
3	1478 30	3071 29	4349 29	4670 28	6268 27	6906 26
4	1480 41	3089 40	4379 39	4703 38	6311 37	6950 36
5	1467 51	3096 50	4396 49	4720 49	6332 47	6971 46
7	1434 72	3072 70	4384 69	4712 69	6344 66	6990 65
9	1378 92	3031 91	4355 89	4686 89	6322 86	6970 85
12	1278 123	2922 122	4252 120	4585 119	6242 116	6897 115
15	1158 154	2810 152	4139 150	4470 150	6127 146	6787 144
20	873 206	2531 204	3871 202	4206 201	5878 197	6546 194
25	557 258	2197 255	3509 253	3839 252	5498 247	6175 244

Flow (GPM)

TORQUE (LB IN) 6175
SPEED (RPM) 244

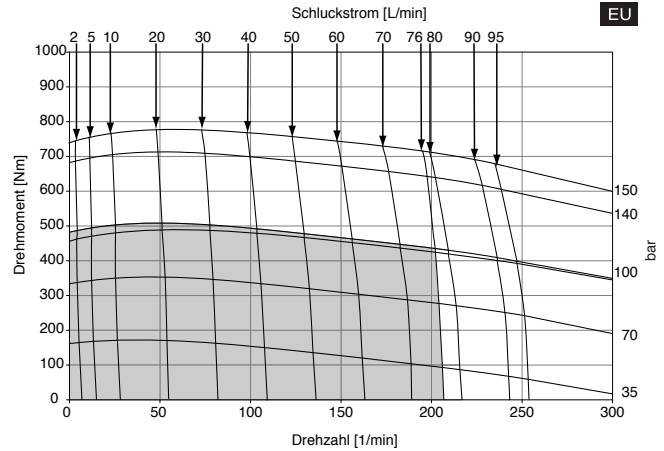

Cont.

Int.

Intermittent operation rating applies to 10% of every minute.

Fonctionnement interm. 10% max. de chaque minute d'utilisation.

Performance data based on testing using 10W40 oil with a viscosity of 200 SUS at 54° C (130° F). Performance data is typical. Actual data may vary slightly from one production motor to another.

Les donnees sur les performances sont basees sur des tests utilisant de l'huile 10W40 d'une viscosite de 200 SUS a 54°C (130°F). Ces donnees correspondent a des situations typiques. Les donnees reelles peuvent varier legerement d'un moteur de production a l'autre.

Intermittierende Werte maximal 10% von jeder Betriebsminute.

Capacidad de funcionamiento intermitente valida para 10% por cada minuto. Leistungsdaten sind gemessen mit SAE 10W40 bei einer Viskositat von 43,1 Cst bei 54°C. Geringfügige Abweichungen von den Katalogerten sind möglich.

Datos tecnicos obtenidos con aceite 10W40 de 200 SUS de viscosidad a 54°C (130°F). Los datos proporcionados son valores tipicos. Los valores exactos reales podrian tener una pequena variacion entre distintos motores.

Flange Mount / Standardgehäuse
Monture à bride(s) / Montaje de brida

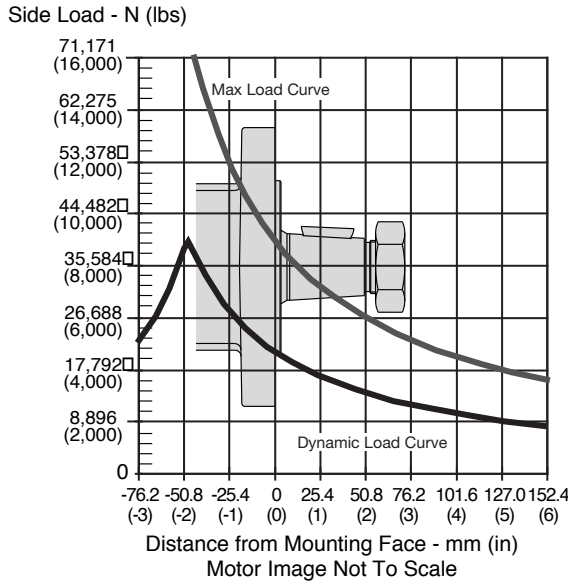

The dynamic side load curve is based on uni-directional steady state loads for L_{10} bearing life at 3×10^6 revolutions.

Die zulässige auslegbare radiale Wellenbelastungskurve ist unter ruhenden, einseitig statisch gerichteten Lastverhältnissen auf eine L_{10} Lebensdauer mit 3×10^6 Umdrehungen kalkuliert. La courbe de charge latérale permise se base sur des charges unidirectionnelles en régime permanent pour le roulement L_{10} à 3×10^6 révolutions. La curva de valores admisibles de carga lateral está basada en cargas constantes para cojinetes L_{10} a 3×10^6 revoluciones.

Equation to Calculate the Expected Radial Bearing Life
Gleichung zur Ermittlung der Lagerlebensdauer

Equation to calculate the dynamic bearing life for a given load:
 Bestimmung der erlaubten radialen Wellenbelastung mit vorgegebener Last

Use F_a , F_b and S in equation to determine hours of L_{10} bearing life.
 Die Lebensdauer in Stunden ergibt sich durch einsetzen von F_a , F_b , und S in die nachstehende Formel.

$$L = \frac{3 \times 10^6}{60 \times S} \left\{ \frac{F_a}{F_b} \right\}^{3.33}$$

Where / Mit:

- S = Shaft Speed RPM / Abtriebswellendrehzahl in min^{-1}
- L = Life In Hours / Lebensdauer in Stunden
- F_a = Dynamic side load defined by above curve at a distance from mounting flange. / Erlaubte radiale Wellenbelastung als Funktion der Länge
- F_b = Application side load. / Anwendungsseitige Wellenbelastung

Note: Calculations are based on L_{10} bearing life per ISO 281.
 Auslegung basiert auf einer L_{10} Lebensdauer nach ISO 281.

Wheel Mount / Radnabengehäuse
Monture à roue / Montaje de rueda

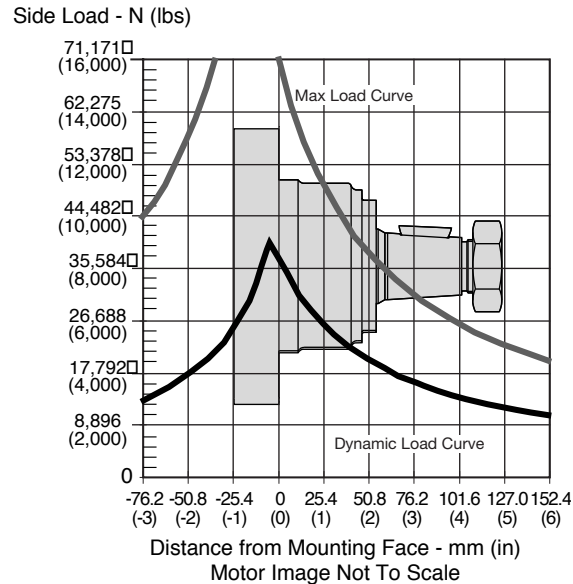

The maximum load curve is defined by bearing static load capacity. This curve should not be exceeded at any time including shock loads.

Die maximale radiale Wellenbelastungskurve ist definiert als maximale statische Last ohne Drehzahl. Sie gilt als Grenze und sollte keinesfalls überschritten werden.

La courbe de charge maximale est définie par la capacité de charge statique portante. Cette courbe ne devrait être dépassée en aucun moment y compris pour les charges par à-coups.

La curva de carga máxima queda definida por la capacidad de carga estática del cojinete. No se deben superar los valores de esta curva, ni siquiera con cargas provisionarias de impacto.

Code: AH

SAE A 2-Bolt, ISO 6149-1 M22 x 1.5

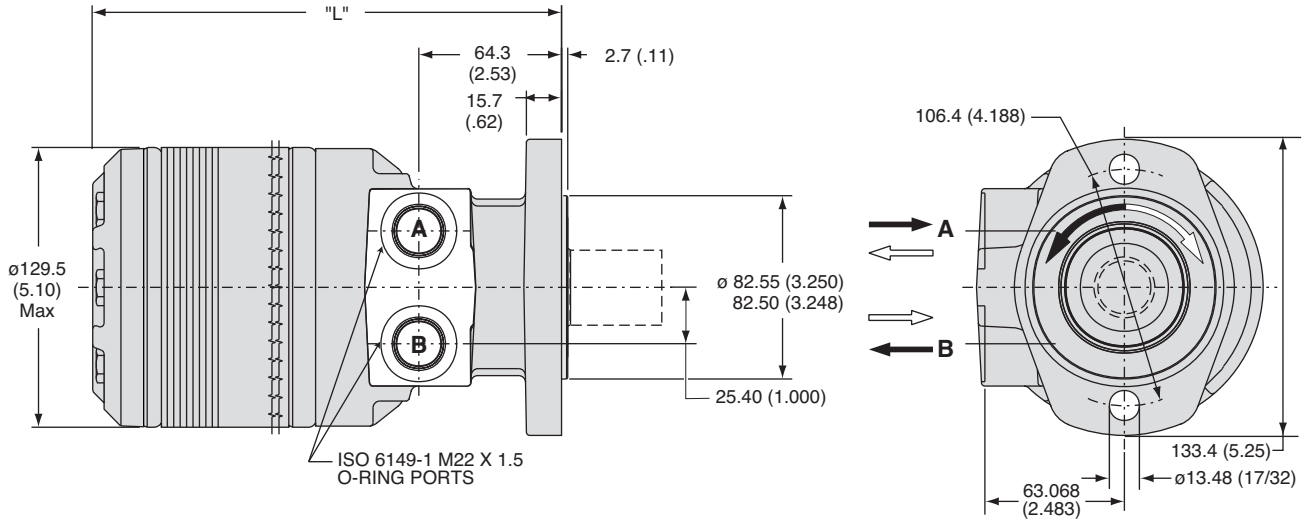

Code AH	disp.	0080	0100	0130	0140	0170	0195	0240	0280	0360	0405	0475
Weight/Gewicht	kg	13.6	13.6	13.8	13.9	14.2	14.5	14.9	15.2	16.0	16.5	17.2
Poids/Peso	(lb)	(29.9)	(30.0)	(30.5)	(30.7)	(31.3)	(31.9)	(32.9)	(33.5)	(35.2)	(36.4)	(37.9)
Length	"L" mm	191	191	194	196	199	202	207	211	221	225	234
	"L" (in)	(7.51)	(7.51)	(7.63)	(7.70)	(7.82)	(7.95)	(8.13)	(8.32)	(8.70)	(8.87)	(9.20)

Code: AM

SAE A 2-Bolt, Manifold

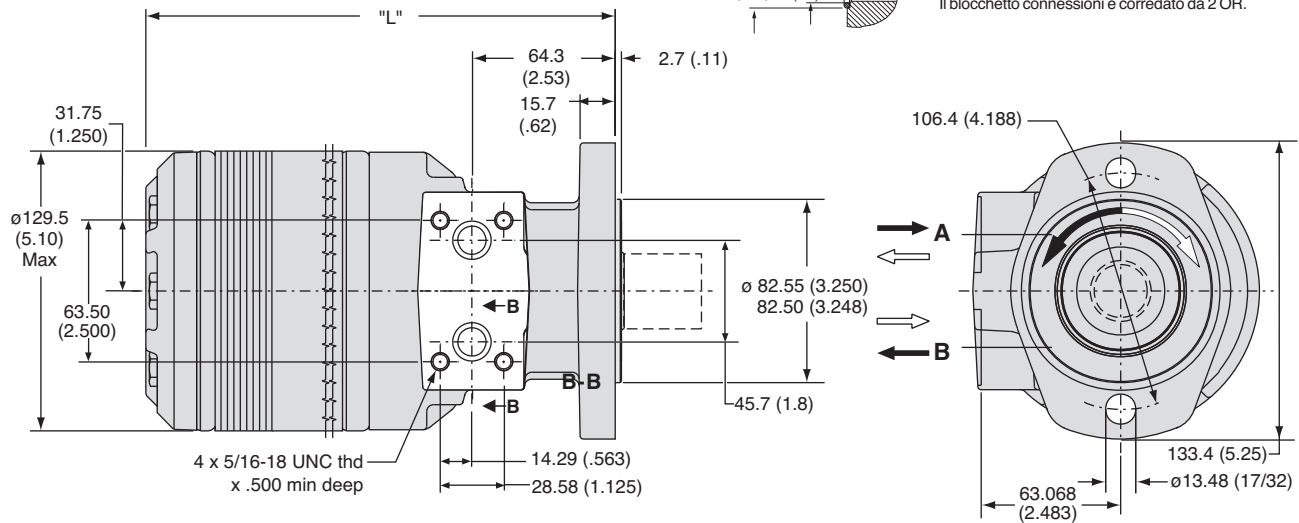

Motor with manifold mount is supplied with 2 o-rings.
Zum Motor mit Universalanschluß werden 2 o-ringe geliefert.
Deux joints toriques sont livrés avec les moteurs a plan de raccordement universel.
Il blocchetto connessioni è correato da 2 OR.

Code AM	disp.	0080	0100	0130	0140	0170	0195	0240	0280	0360	0405	0475
Weight/Gewicht	kg	13.6	13.6	13.8	13.9	14.2	14.5	14.9	15.2	16.0	16.5	17.2
Poids/Peso	(lb)	(29.9)	(30.0)	(30.5)	(30.7)	(31.3)	(31.9)	(32.9)	(33.5)	(35.2)	(36.4)	(37.9)
Length	"L" mm	191	191	194	196	199	202	207	211	221	225	234
	"L" (in)	(7.51)	(7.51)	(7.63)	(7.70)	(7.82)	(7.95)	(8.13)	(8.32)	(8.70)	(8.87)	(9.20)

English equivalents for metric specifications are shown in ().

Code: AS

SAE A 2-Bolt, 7/8-14 SAE O-Ring

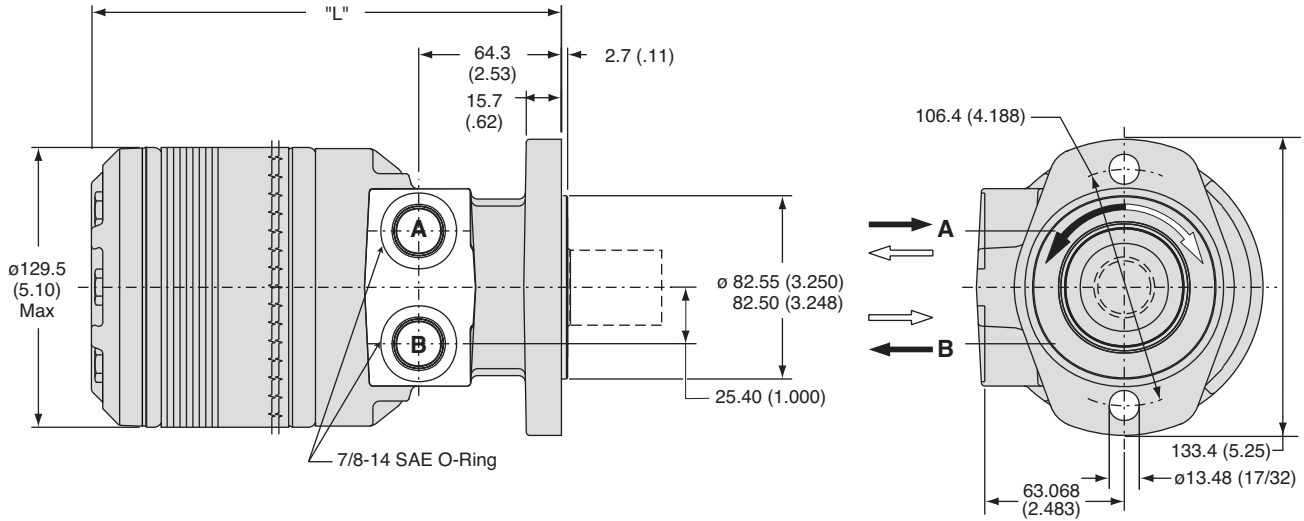

Code AS	disp.	0080	0100	0130	0140	0170	0195	0240	0280	0360	0405	0475
Weight/Gewicht	kg	13.6	13.6	13.8	13.9	14.2	14.5	14.9	15.2	16.0	16.5	17.2
Poids/Peso	(lb)	(29.9)	(30.0)	(30.5)	(30.7)	(31.3)	(31.9)	(32.9)	(33.5)	(35.2)	(36.4)	(37.9)
Length	"L" mm	191	191	194	196	199	202	207	211	221	225	234
	"L" (in)	(7.51)	(7.51)	(7.63)	(7.70)	(7.82)	(7.95)	(8.13)	(8.32)	(8.70)	(8.87)	(9.20)

Code: BS

SAE B 2-Bolt, 7/8-14 SAE O-Ring

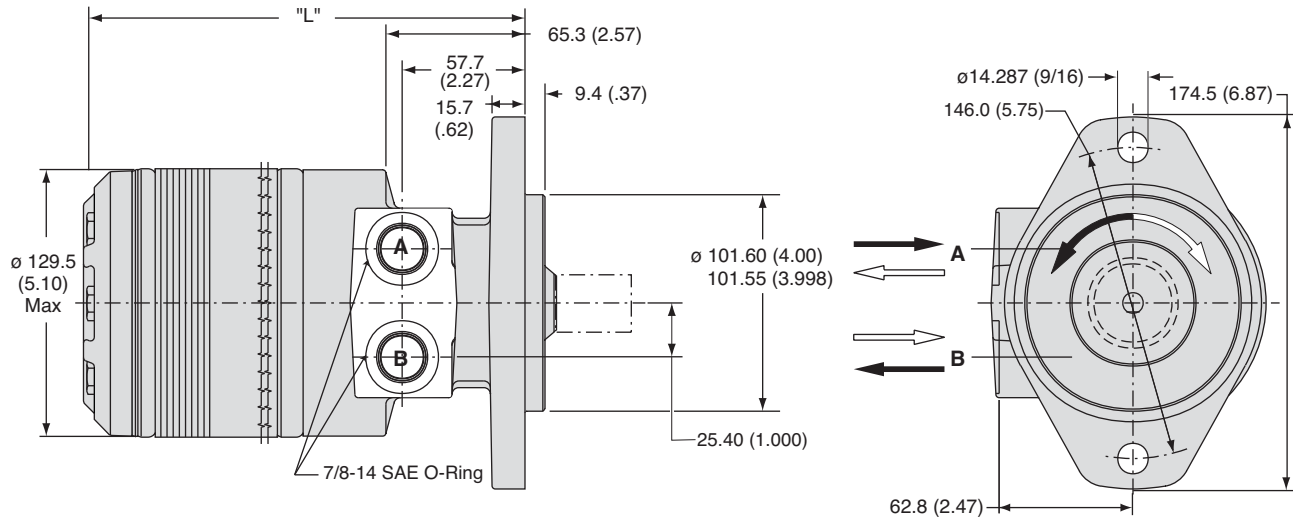

Code BS	disp.	0080	0100	0130	0140	0170	0195	0240	0280	0360	0405	0475
Weight/Gewicht	kg	14.2	14.2	14.5	14.6	14.8	15.1	15.5	15.8	16.6	17.1	17.8
Poids/Peso	(lb)	(31.3)	(31.4)	(31.9)	(32.1)	(32.7)	(33.3)	(34.3)	(34.9)	(36.6)	(37.8)	(39.3)
Length	"L" mm	184	184	187	189	192	195	200	205	214	218	227
	"L" (in)	(7.25)	(7.25)	(7.37)	(7.44)	(7.56)	(7.69)	(7.87)	(8.06)	(8.44)	(8.60)	(8.94)

English equivalents for metric specifications are shown in ().

Code: LS

Wheel, Front Brake Nose

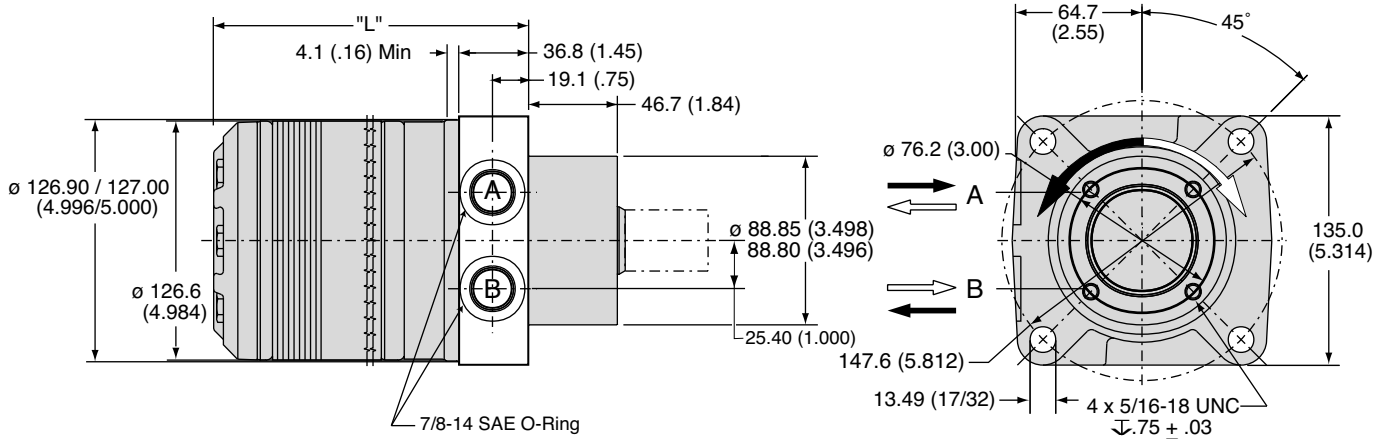

Code LS	disp.	0080	0100	0130	0140	0170	0195	0240	0280	0360	0405	0475
Weight/Gewicht	kg	14.0	14.0	14.2	14.3	14.6	14.9	15.3	15.6	16.3	17.0	17.5
Poids/Peso	(lb)	(30.9)	(30.9)	(31.2)	(31.5)	(32.1)	(32.9)	(33.7)	(34.4)	(35.9)	(37.5)	(38.6)
Length	"L" mm	146	146	149	151	154	157	162	167	175	180	189
	"L" (in)	(5.73)	(5.73)	(5.85)	(5.92)	(6.04)	(6.17)	(6.35)	(6.54)	(6.92)	(7.08)	(7.42)

Code: MS

Magneto, 7/8-14 SAE O-Ring

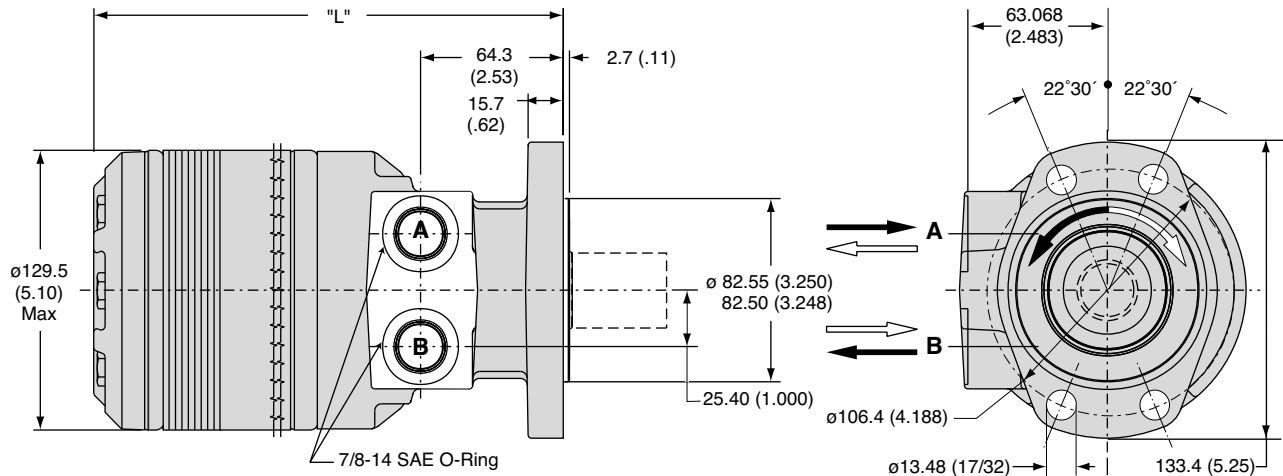

Code MS	disp.	0080	0100	0130	0140	0170	0195	0240	0280	0360	0405	0475
Weight/Gewicht	kg	13.6	13.6	13.8	13.9	14.2	14.5	14.9	15.2	16.0	16.5	17.2
Poids/Peso	(lb)	(29.9)	(30.0)	(30.5)	(30.7)	(31.3)	(31.9)	(32.9)	(33.5)	(35.2)	(36.4)	(37.9)
Length	"L" mm	191	191	194	196	199	202	207	211	221	225	234
	"L" (in)	(7.51)	(7.51)	(7.63)	(7.70)	(7.82)	(7.95)	(8.13)	(8.32)	(8.70)	(8.87)	(9.20)

English equivalents for metric specifications are shown in ().

008 TF.indd, js

Code: US

Wheel, Standard, 7/8-14 SAE O-Ring

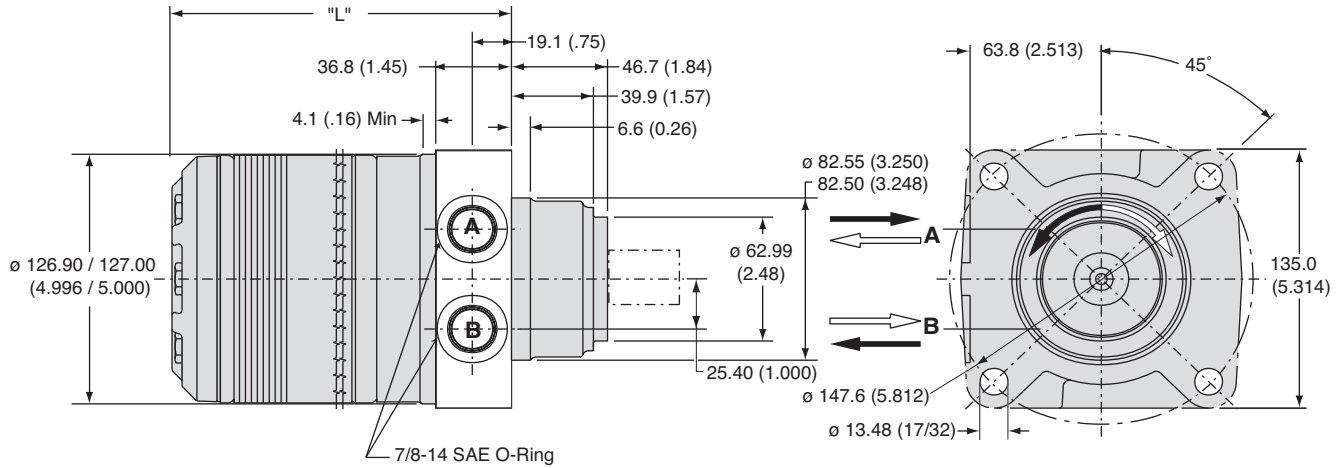

Code US	disp.	0080	0100	0130	0140	0170	0195	0240	0280	0360	0405	0475
Weight/Gewicht	kg	13.9	13.9	14.2	14.3	14.5	14.8	15.2	15.5	16.3	16.9	17.5
Poids/Peso	(lb)	(30.6)	(30.7)	(31.2)	(31.5)	(32.0)	(32.7)	(33.6)	(34.2)	(35.9)	(37.2)	(38.6)
Length	"L" mm	146	146	149	151	154	157	162	167	176	180	189
	"L" (in)	(5.73)	(5.73)	(5.85)	(5.92)	(6.04)	(6.17)	(6.35)	(6.54)	(6.92)	(7.08)	(7.42)

Code: VB

SAE A 4-Bolt, 7/8-14 SAE Rear Port

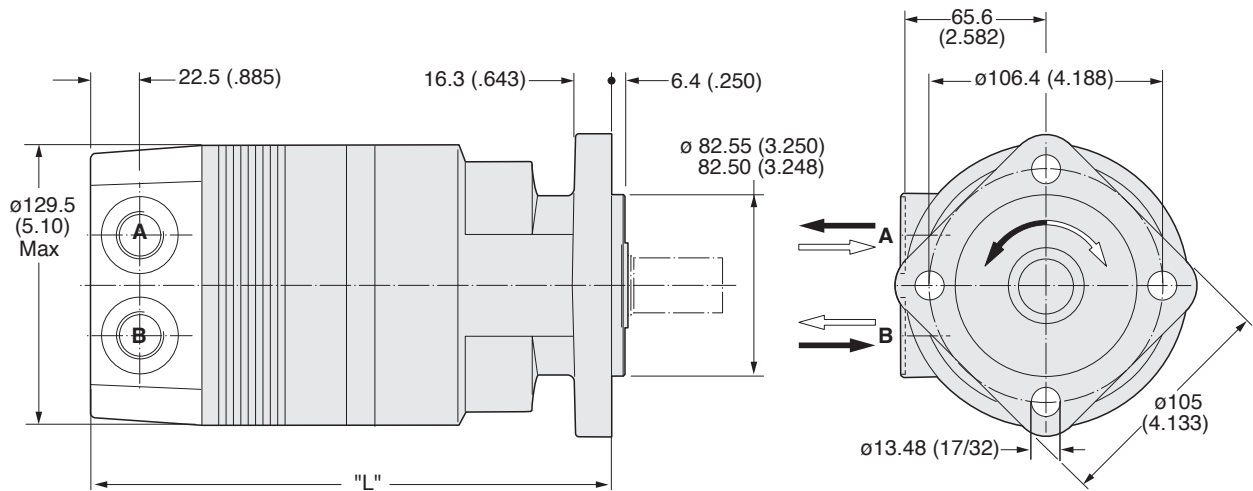

Code VB	disp.	0080	0100	0130	0140	0170	0195	0240	0280	0360	0405	0475
Weight/Gewicht	kg	14.0	14.0	14.2	14.3	14.6	14.9	15.3	15.6	16.3	17.0	17.5
Poids/Peso	(lb)	(30.9)	(30.9)	(31.2)	(31.5)	(32.1)	(32.9)	(33.7)	(34.4)	(35.9)	(37.5)	(38.6)
Length	"L" mm	213	213	216	218	221	224	229	233	242	247	256
	"L" (in)	(8.39)	(8.39)	(8.49)	(8.60)	(8.70)	(8.82)	(9.02)	(9.17)	(9.53)	(9.72)	(10.08)

English equivalents for metric specifications are shown in ().

008 TF.indd, js

Code: WE

Wheel, Optional, Manifold Rear Port

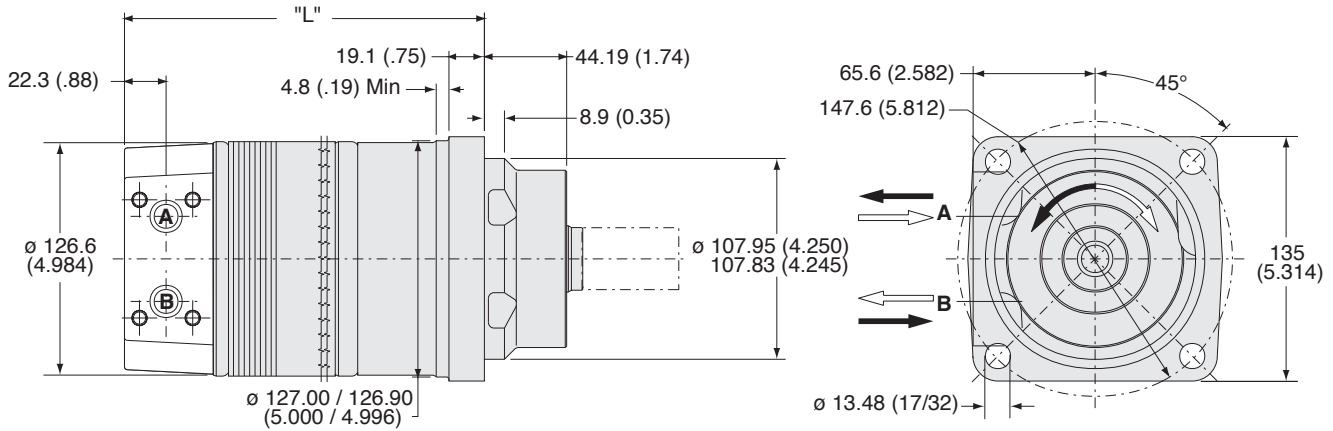

Code WB	disp.	0080	0100	0130	0140	0170	0195	0240	0280	0360	0405	0475
Weight/Gewicht	kg	16.9	16.9	17.2	17.3	17.5	17.8	18.2	18.5	19.3	19.8	20.5
	Poids/Peso lb	37.2	37.3	37.8	38.0	38.6	39.2	40.2	40.8	42.5	43.7	45.2
Length	"L" mm	173	173	176	178	181	184	189	194	203	207	216
	"L" in	6.80	6.80	6.93	6.99	7.11	7.24	7.43	7.61	7.99	8.15	8.49

Code: DB

Large Wheel Mount, 7/8-14 SAE Rear Port

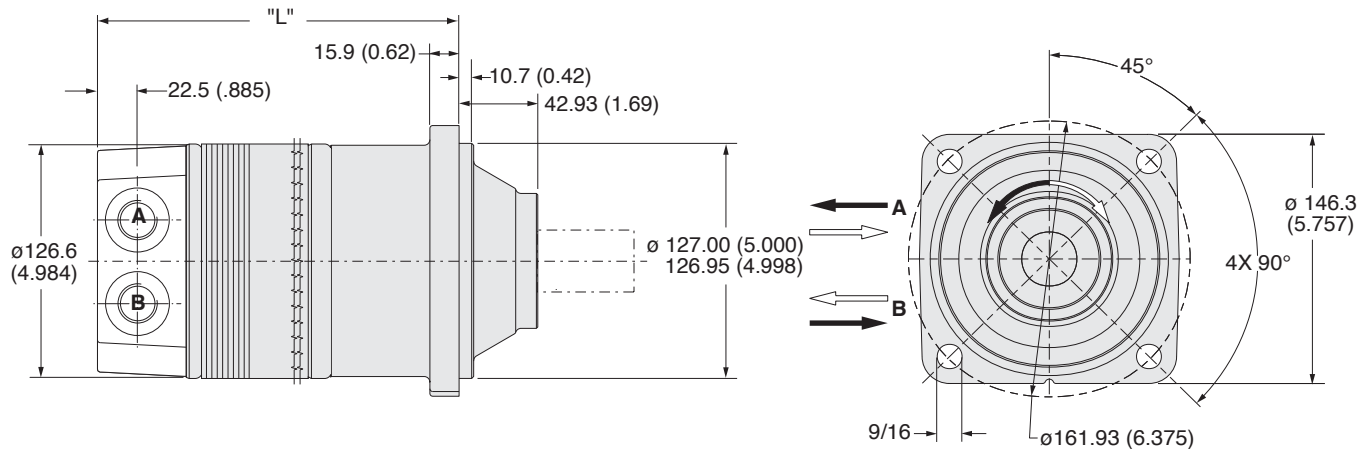

Code DB	disp.	0080	0100	0130	0140	0170	0195	0240	0280	0360	0405	0475
Weight/Gewicht	kg	16.9	16.9	17.2	17.3	17.5	17.8	18.2	18.5	19.3	19.8	20.5
	Poids/Peso lb	37.2	37.3	37.8	38.0	38.6	39.2	40.2	40.8	42.5	43.7	45.2
Length	"L" mm	173	173	176	179	182	185	190	195	201	209	217
	"L" (in)	(6.81)	(6.81)	(6.91)	(7.04)	(7.17)	(7.29)	(7.48)	(7.67)	(7.91)	(8.21)	(8.54)

English equivalents for metric specifications are shown in ().

008 TF.indd, js

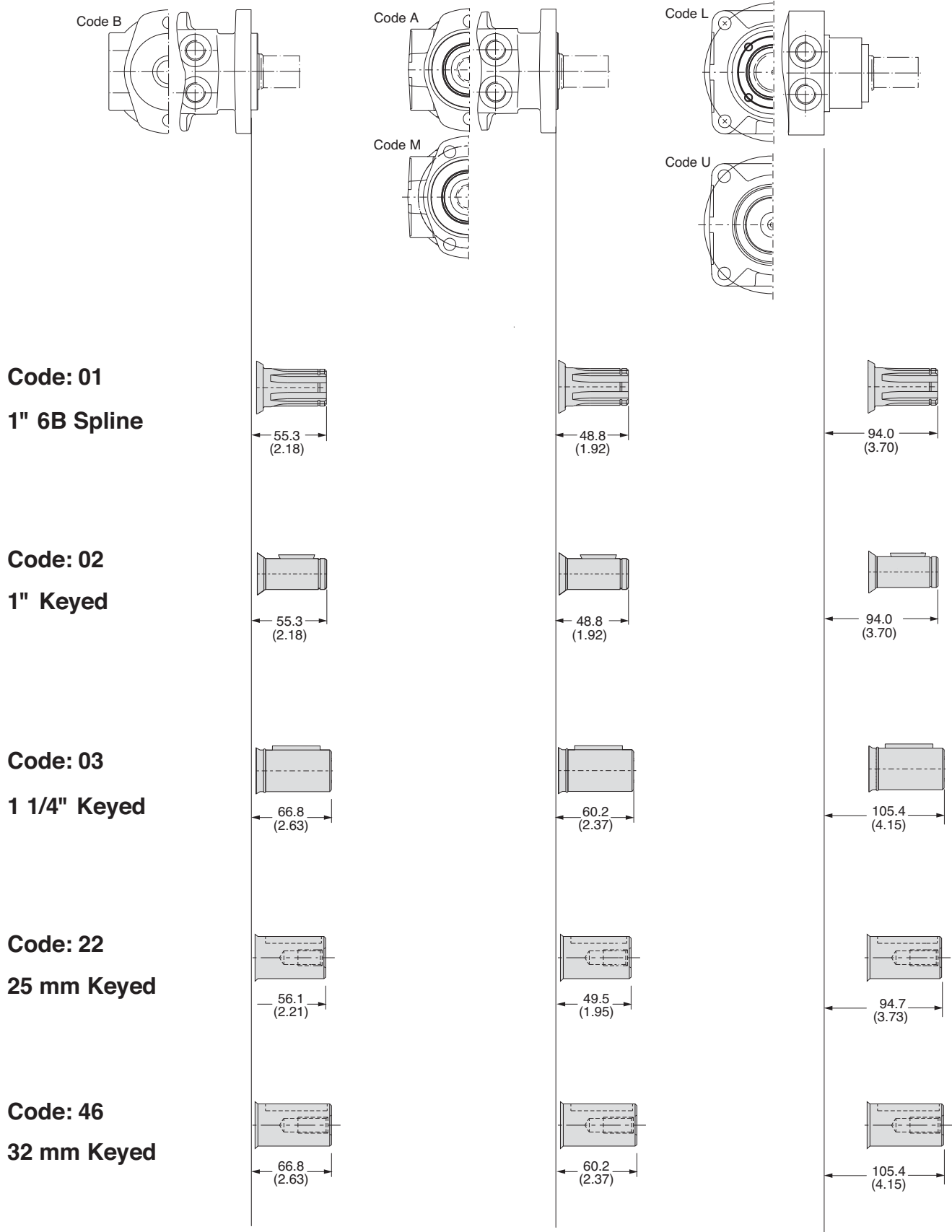

English equivalents for metric specifications are shown in ().

008 TF.indd, js

Code: 01
1" 6B Spline

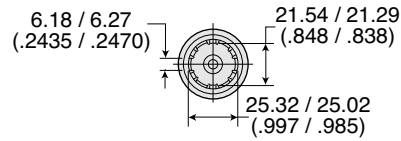
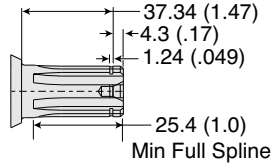

Code: 02
1" Keyed

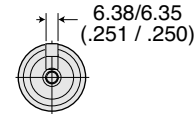
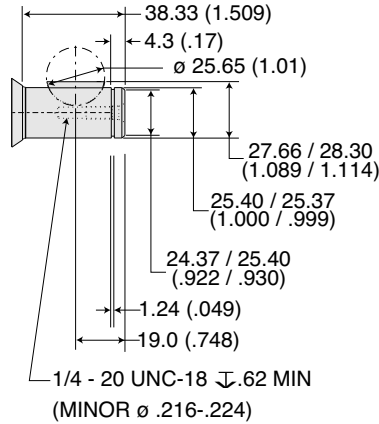

Code: 03
1 1/4" Keyed

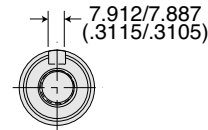
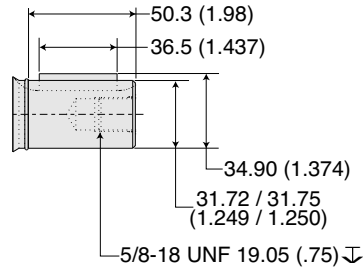

Code: 22
25 mm Keyed

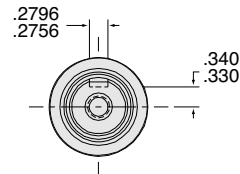
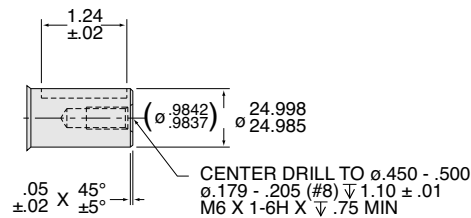

Code: 46
32 mm Keyed

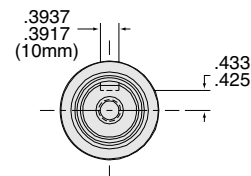
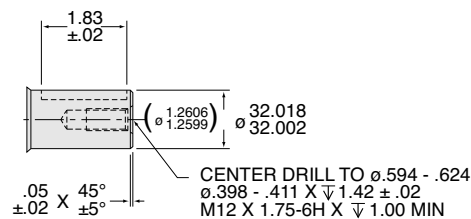

English equivalents for metric specifications are shown in ().

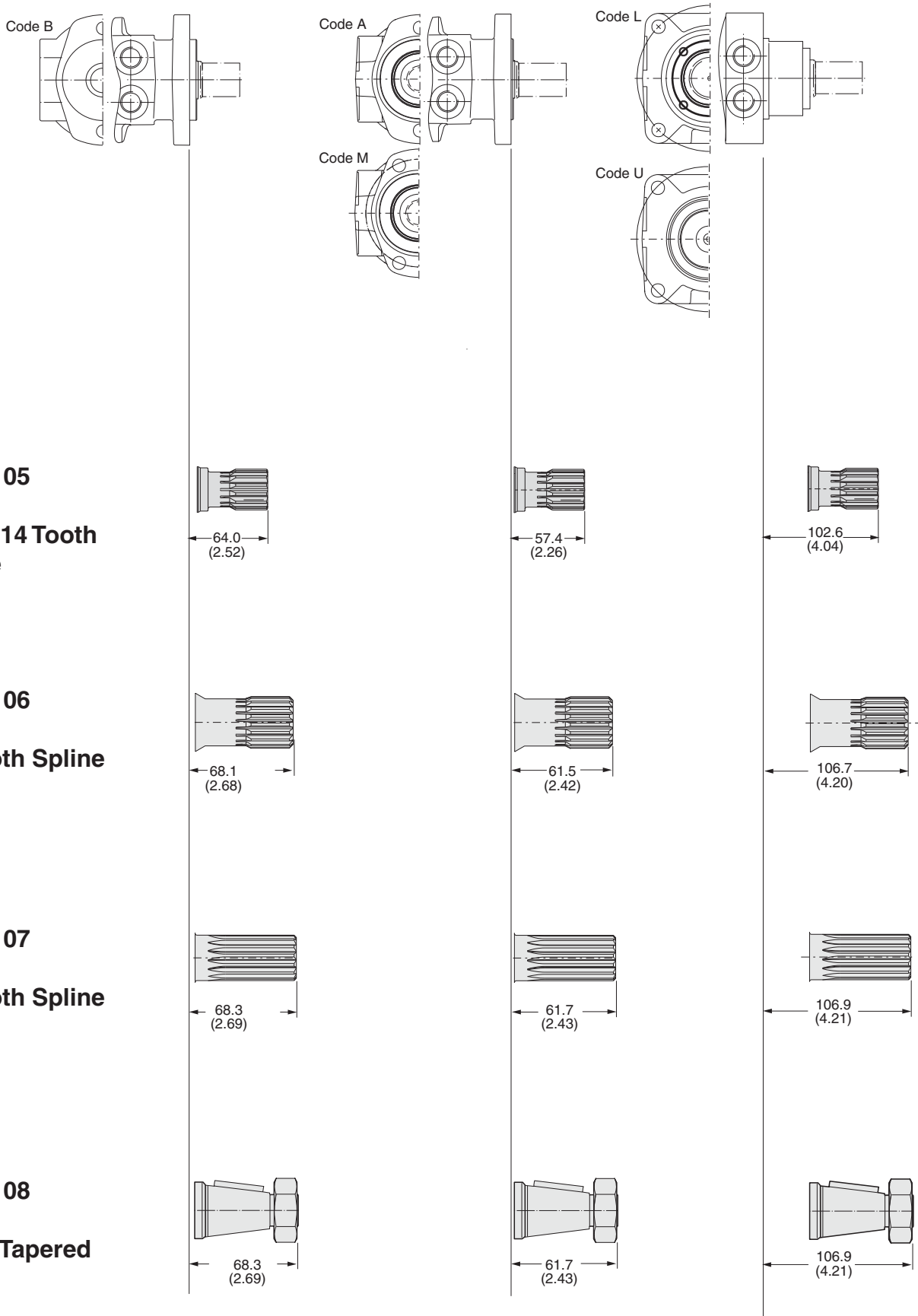

English equivalents for metric specifications are shown in ().

008 TF.indd, js

Code: 05
1 1/4" 14 Tooth Spline

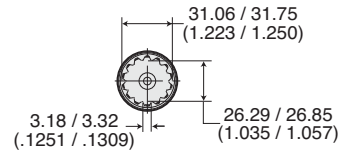
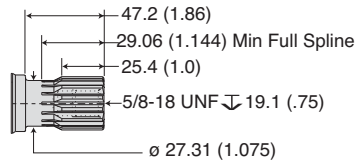

Code: 06
19 Tooth Spline

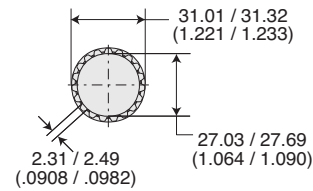
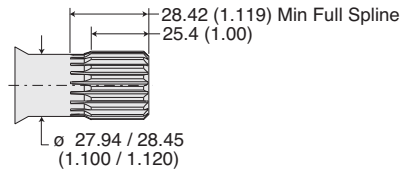

Code: 07
15 Tooth Spline

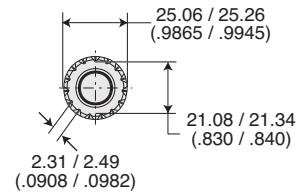
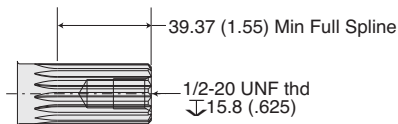

Code: 08
1 1/4" Tapered

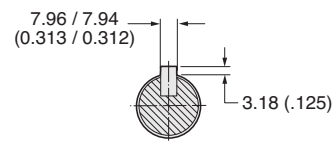
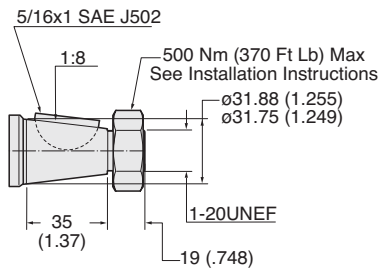

English equivalents for metric specifications are shown in ().

008 TF.indd, js